

Technical Datasheet for RRK 1000 WID with combustion TSRF

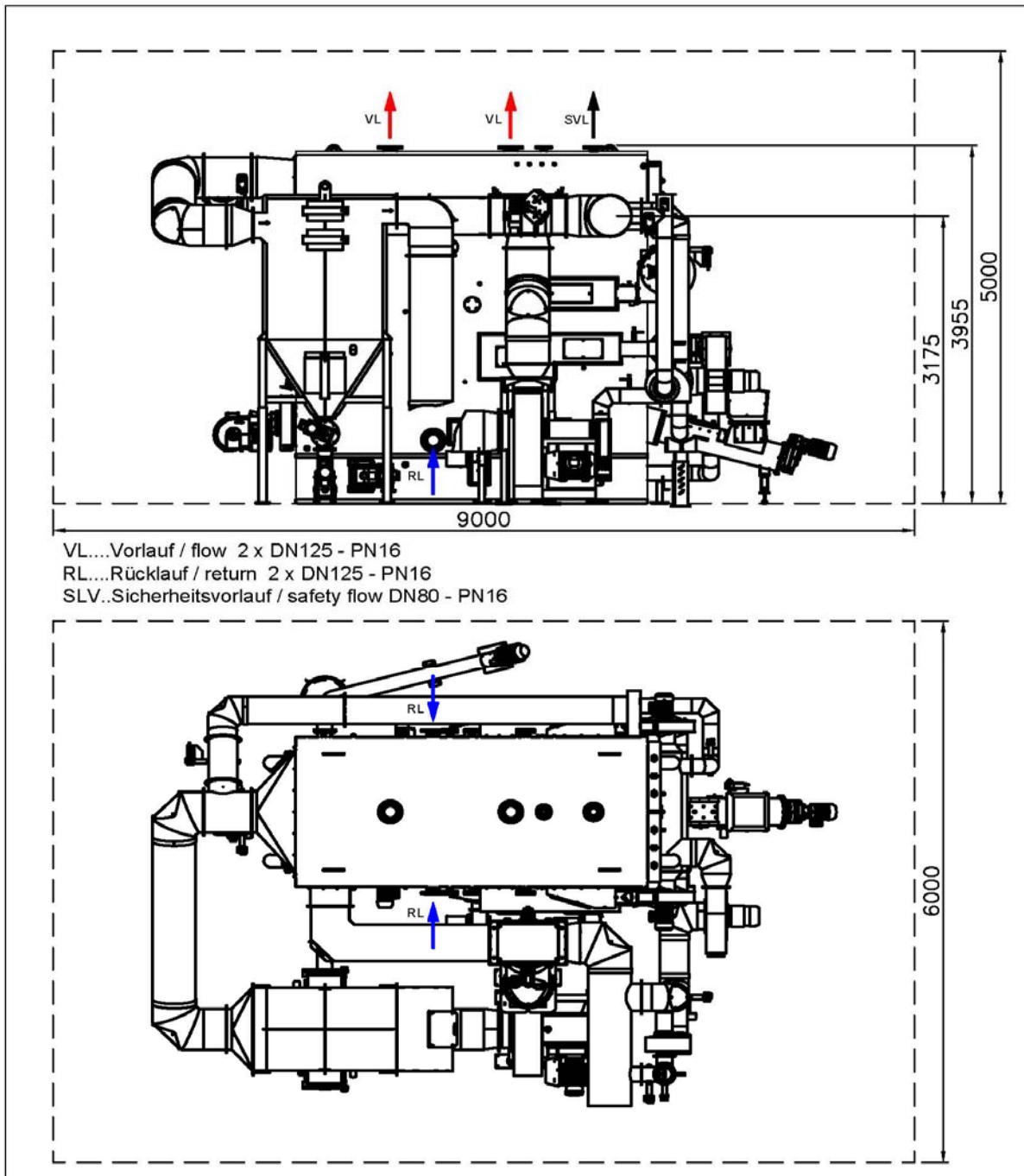

Notes

Min. required inlet opening for boiler installation in one piece (lxwxh)	mm	4.200 x 2.500 x 3.600
Min. required inlet opening for divided boiler installation (lxwxh)	mm	4.200 x 2.500 x 3.050

Questions concerning the transfer of the vessel into the boiler room have to be discussed with the Herz.
 Schematic drawing. Vessel will be customized for the customers needs.

Herz operating conditions shall apply. Conditions for combustion type TSRF

Technical changes reserved

Technical Datasheet for RRK 1000 WID

with combustion TSRF

Performance data		max. nominal output PN		kW	1000
		max. output PF		kW	1124
Combustion data		grate surface		m ²	3,00
		combustion chamber volume	A	m ³	4,7
		heat exchanger surface		m ²	104
	6 bar	total weight with water	B	kg	20425
		total weight without water	B	kg	16035
		boiler block	C	kg	13480
	10 bar	total weight with water	B	kg	21795
		total weight without water	B	kg	17405
		boiler block	C	kg	14850
			combustion	C	kg
		refractory clay	D	kg	5475
Dimensions		combustion [l x w x h]	E	mm	4.000 x 2.300 x 560
		boiler block [l x w x h]	E;F	mm	3.840 x 1.770 x 2.840
		complete [l x w x h]	E;F	mm	4.000 x 2.300 x 3.400
Hydraulic connections		flow	G	Zoll, DN	2 x DN125 - PN16
		return	G	Zoll, DN	DN125 - PN16
		safety flow	H	Zoll, DN	DN50 - PN16
		safety heat exchanger	I	Zoll	2 x 1"
		socket for thermostat		Zoll, DN	8 x 1/2"
		drain		Zoll, DN	2 x 5/4"
		water content		l	4390
		resistance at Δt 20°		mbar	58
		flow at Δt 20°		m ³ /h	51,6
		min. pump flow		m ³ /h	62
Electric connections		primary fan		kW	2,2 & 0,75
		sekundary fan		kW	2 x 1,5
		exhaust gas fan (without HV)		kW	11
		exhaust gas fan (with HV)		kW	18,5
		flue diameter	J	mm	450
		flue area		m ²	0,1590
		draft	K	Pa	10
		exhaust gas temperature	L	°C	170-190
		M30 / W30	M	Bm ³ /h	4100

Notes

- A** Total combustion volume until heat exchanger entry
- B** Weight of combustion, boiler block and refractory including doors and casing
- C** Weight including refractory, doors and casing
- D** Weight of refractory including concrete and burning chamber interior isolation
- E** Dimensions including mounted doors
- F** Boiler block will be in pieces from boiler range 1800-2300 upwards.
- G** All existing flanges must be connected (for boiler types RRK 22-49 and RRK 80-175 only 1 return flange has to be connected)
- H** Safety valve has to be dimensioned, provided and mounted by the customer and has to comply with local laws and other governmental enactments
- I** The mounting of the thermal safety valve including the piping has to be done by the customer.
- J** Chimney diameter and height and also the cleaning openings have to be approved by local authorities.
- K** The vessel is equipped with a flue gas fans, which assures the necessary vacuum into then combustion chamber.
- L** Flue gas temperature depends on the used combustible and the operating state (part or full load) and also of the degree of pollution of the heat exchanger.
- M** Flue gas volume at λ 1,6 (8% residual oxygen) and 180°C flue gas temperature

Version: V01 | Datum: 30.5.2017

Myriad Heat & Power Products Ltd

Design / Project Management / Distribution / Servicing / Training

Registered in England No. 07691864 VAT Reg No. 251 3161 43

Myriad Heat & Power Products Ltd, Unit 21 Burrough Court, Burrough on the Hill, Melton Mowbray, Leics. LE14 2QS